

Wireshark

Area de Ingeniería Telemática
<http://www.tlm.unavarra.es>

Area de Teoría de la Señal y Comunicaciones
<http://csm.unavarra.es>

Grado en Ingeniería en Tecnologías de Telecomunicación, 3º

HSPA

Recordemos....

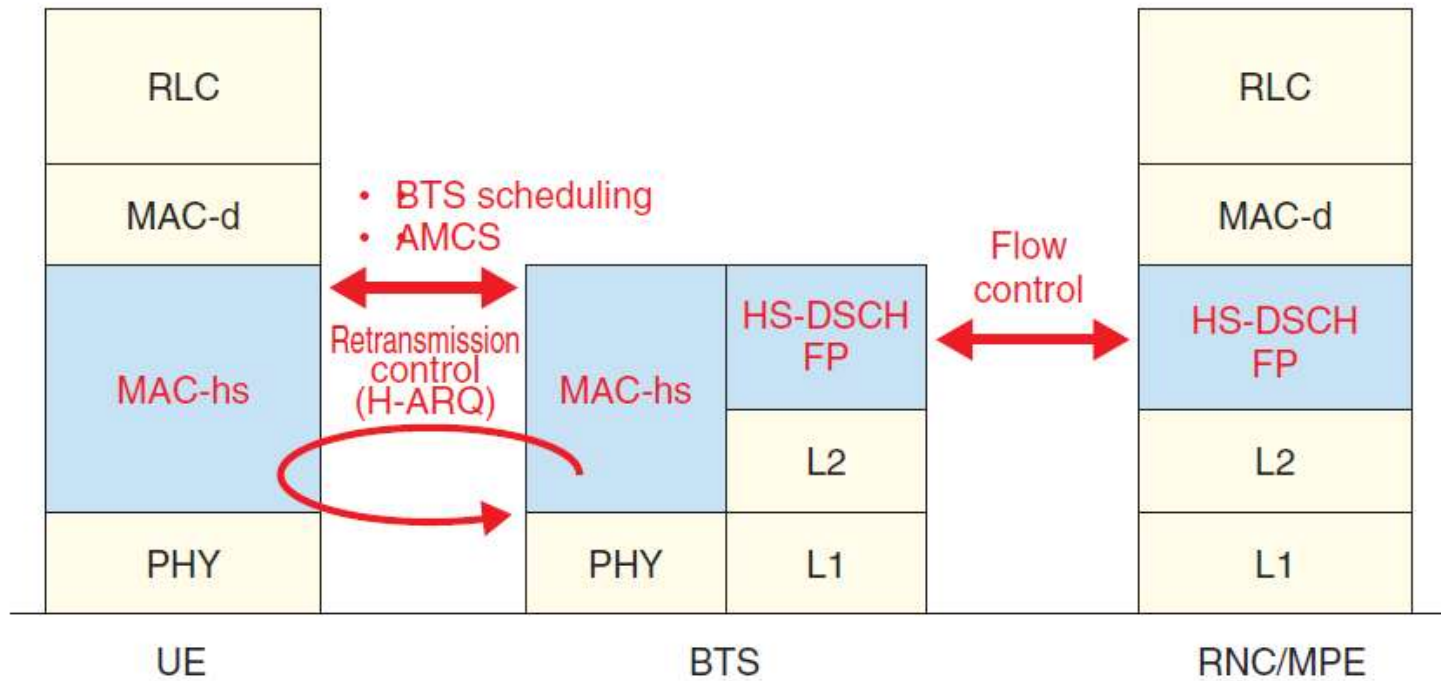

MAC-HS: Subcapa MAC HSPA

MAC-d: Subcapa dedicada MAC

HS-DSCH:

Transmisión de Paquetes-LTE

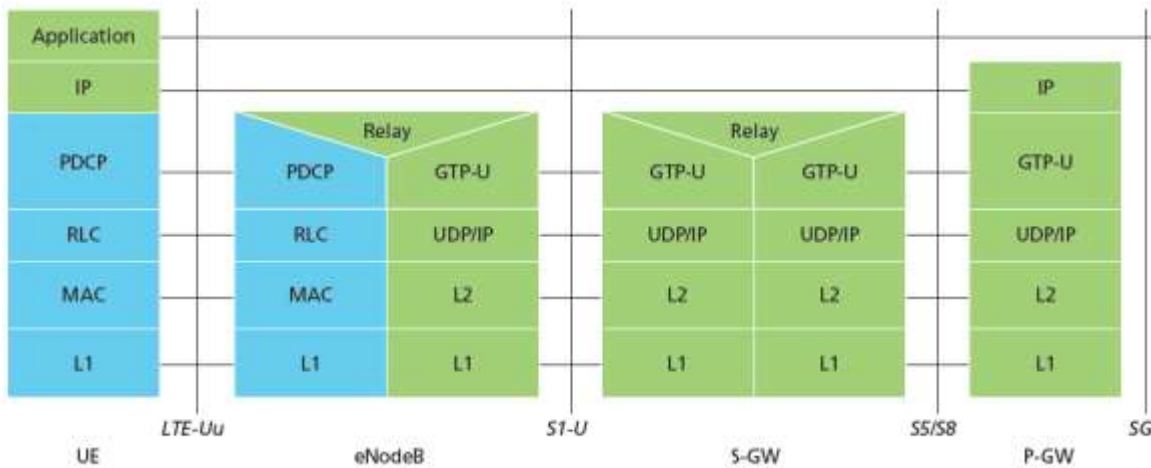

Pila de Protocolo
 Plano de Usuario

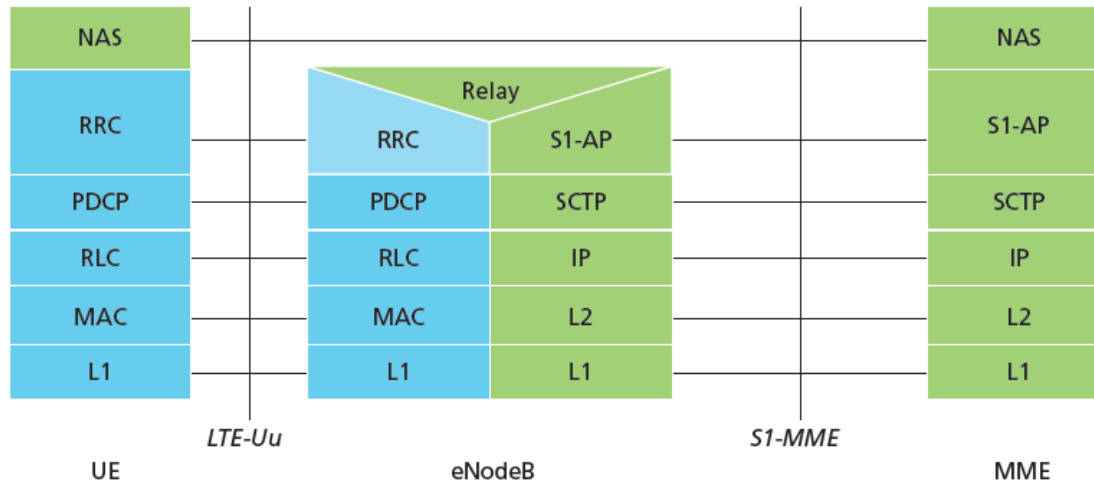

Pila de Protocolo
 Plano de Control

Wireshark+Dissectors

No.	Time	DCT time	Source	Destination	Protocol	UL Grant	UL Retx	Info
31	31.792600	500.6438			MAC-LTE			RACH Preamble sent for UE 1 (RAPID=0, attempt=1)
33	0.011100	500.6549			MAC-LTE			RAR (RA-RNTI=2, SF=6) (RAPID=0; TA=0, UL-Grant=52248, Temp C-RNTI=39897)
37	0.001500	500.6564			MAC-LTE	15		UL-SCH: (SF=6) UEId=1 (CCCH:6 bytes) (Padding:remainder) RRCConnectionRequest
39	0.013500	500.6699			MAC-LTE			DL-SCH: (SF=1) UEId=1 (UE Contention Resolution Identity) (CCCH:27 bytes) (Padding:remainder) RRCConnectionSetup
42	0.003400	500.6733			MAC-LTE			Scheduling Request sent for UE 1 (C-RNTI=39897)
45	0.019100	500.6924			MAC-LTE	177		UL-SCH: (SF=4) UEId=1 (Short BSR) (1:28 bytes) (Padding:remainder)
72	0.009500	500.7019			MAC-LTE			DL-SCH: (SF=3) UEId=1 (1:2 bytes) (Padding:remainder)
74	0.005000	500.7069			MAC-LTE			DL-SCH: (SF=8) UEId=1 (1:10 bytes) (Padding:remainder)
77	0.000400	500.7073			MAC-LTE			Scheduling Request sent for UE 1 (C-RNTI=39897)
83	0.025000	500.7323			MAC-LTE	177		UL-SCH: (SF=4) UEId=1 (Short BSR) (1:2 bytes) (1:18 bytes) (Padding:remainder)

Frame 83: 91 bytes on wire (728 bits), 91 bytes captured (728 bits)

Catapult DCT2000 packet context=sector-11451.2 t=500.7323 s prot=mac_r8_lte (v=1)

MAC-LTE

- [Radio Type: TDD (2)]
- [Direction: Uplink (0)]
- [UEId: 1]
- [Subframe: 4]
- [RNTI: 39897]
- [RNTI Type: C-RNTI (3)]
- [Length of frame: 177]
- [Uplink grant size: 177]
- [First Grant Following SR from: 77]
- [Time since SR (ms): 25]
- MAC PDU Header (4 subheaders)
- Short BSR (lcgid=0 BS = 0)
- RLC-LTE UEId=1 (SRB:1) [AM] [CONTROL] ACK_SN=1
- RLC-LTE UEId=1 (SRB:1) [AM] [DATA] (P) (SN=1) [16-bytes]**
- [Padding length: 150]

```

0000 73 65 63 74 6f 72 2d 31 31 34 35 31 00 02 35 30 sector-1 1451..50
0010 30 2e 37 33 32 33 00 6d 61 63 5f 72 38 5f 6c 74 0.7323.m ac_r8_lte
0020 65 00 31 00 31 2c 33 2c 30 2c 34 2c 30 2c 33 39 e.1.1.3, 0.4,0.39
0030 38 39 37 2c 31 2c 31 37 37 2c 30 2c 30 00 00 00 897,1,17 7,0,0...
0040 3d 21 02 21 12 1f 00 00 04 30 01 01 38 00 00 e0 =!..!... ..8..
0050 20 00 00 00 00 00 00 00 00 00 00 00 00 00 00 .....
  
```

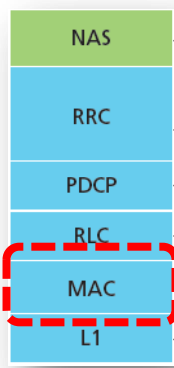

LTE-MAC

<http://wiki.wireshark.org/MAC-LTE>

Wireshark+Dissectors

No.	Time	DCT Time	Grant size	Source	Dest	retx	Protocol	Info
12955	162.252600	162.349					RLC-LTE	[UL] [TM] UEID=3 CCCCRRCCConnectionRequest
12998	0.701600	163.0506					RLC-LTE	[DL] [TM] UEID=3 CCCCRRCCConnectionSetup
13010	0.032400	163.083					PDCCP-LTE/NAS	[UL] [AM] UEID=3 SRB:1 [DATA] (P) sn=0 Signalling: sn=0 RRCConnectionSetupComplete MAC=0x00000000 (21 bytes data) [26-bytes]
13034	0.009500	163.0925					RLC-LTE	[DL] [AM] UEID=3 SRB:1 [CONTROL] ACK_SN=1
13071	0.462000	163.5545					PDCCP-LTE	[DL] [AM] UEID=3 SRB:1 [DATA] (P) sn=0 Signalling: sn=0 SecurityModeCommand MAC=0x349a8c78 (3 bytes data) [8-bytes]
13106	0.088400	163.6429					RLC-LTE	[UL] [AM] UEID=3 SRB:1 [CONTROL] ACK_SN=1
13109	0.000100	163.643					PDCCP-LTE	[UL] [AM] UEID=3 SRB:1 [DATA] (P) sn=1 Signalling: sn=1 SecurityModeComplete MAC=0x9339e625 (2 bytes data) [7-bytes]
13116	0.009500	163.6525					RLC-LTE	[DL] [AM] UEID=3 SRB:1 [CONTROL] ACK_SN=2
13160	0.459000	164.1115					PDCCP-LTE	[DL] [AM] UEID=3 SRB:1 [DATA] (P) sn=1 Signalling: sn=1 MAC=0xa95df1f8 (110 bytes data) [115-bytes]
13177	0.011400	164.1229					RLC-LTE	[UL] [AM] UEID=3 SRB:1 [CONTROL] ACK_SN=2
13180	0.000000	164.1229					PDCCP-LTE	[UL] [AM] UEID=3 SRB:1 [DATA] (P) sn=2 Signalling: sn=2 MAC=0xcddffc09 (2 bytes data) [7-bytes]
13188	0.009600	164.1325					RLC-LTE	[DL] [AM] UEID=3 SRB:1 [CONTROL] ACK_SN=3
26865	162.621000	326.7535					RLC-LTE	[UL] [AM] UEID=3 DRB:3 [DATA] (P) sn=0 [94-bytes]
26875	0.009500	326.763					RLC-LTE	[DL] [AM] UEID=3 DRB:3 [CONTROL] ACK_SN=1
28579	18.620800	345.3838					RLC-LTE	[DL] [AM] UEID=3 DRB:3 [DATA] (P) sn=0 [130-bytes]
28593	0.087500	345.4713					RLC-LTE	[UL] [AM] UEID=3 DRB:3 [CONTROL] ACK_SN=1
85056	100.714600	446.1859					RLC-LTE	[UL] [AM] UEID=3 DRB:3 [DATA] sn=1 [130-bytes] [40-bytes..
85473	0.045900	446.2318					RLC-LTE	[UL] [AM] UEID=3 DRB:3 [DATA] sn=2 ..90-bytes] [120-bytes..
85551	0.008800	446.2398					RLC-LTE	[UL] [AM] UEID=3 DRB:3 [DATA] sn=3 ..10-bytes] [130-bytes] [69-bytes..
85628	0.008800	446.2478					RLC-LTE	[UL] [AM] UEID=3 DRB:3 [DATA] sn=4 ..61-bytes] [130-bytes] [18-bytes..
85693	0.018000	446.2558					RLC-LTE	[UL] [AM] UEID=3 DRB:3 [DATA] sn=5 ..61-bytes] [130-bytes] [18-bytes..

```

Frame 85551 (271 bytes on wire, 271 bytes captured)
  Catapult DCT2000 packet context=sector-11451.1 t=446.2398 S prot=rlc_r8_lte (v=1)
    RLC-LTE UEID=3 (DRB:3) [AM] [DATA] (SN=3) ..10-bytes] [130-bytes] [69-bytes..
      [Direction: Uplink (0)]
      [RLC Mode: Acknowledged Mode (4)]
      [UEID: 3]
      [Priority: 1]
      [Channel Type: DRB (5)]
      [Channel ID: 3]
      [PDU Length: 214]
      AM header (SN=3)
      Extension Part (length=10)
      Extension Part (length=130)
      AM Data: 00045970B0552B986B1A5D90AB41C91003928554D3C670EF...
      AM Data: 8005C0A379CB076081769B73004452B6C0AFCF2A0405A5CC...
  
```

```

0000 73 65 63 74 6f 72 2d 31 31 34 35 31 00 01 34 34 sector-1 1451..44
0010 36 2e 32 33 39 38 00 72 6c 63 5f 72 38 5f 6c 74 6.2398.r lc_r8_lt
0020 65 00 31 00 34 2c 30 2c 31 2c 31 30 2c 33 2c 35 e.1.4.0, 1,10,3,5
0030 2c 33 2c 32 31 34 00 00 00 9c 03 80 a0 82 cd aa ,3,214...
0040 88 18 1f 58 38 e6 e3 cc 80 04 59 70 8c 5b 2b 88 ...X8... Yp.UH
0050 5b 1a 5d 90 a8 41 c5 1d 03 92 85 54 d3 c6 70 ef ...].A...T..P.
0060 40 44 e0 62 06 25 40 92 bd 7a 4d 44 12 49 ec 35 0D.b.g. .2MD.1.5
0070 f8 1a ac cb a7 bc a3 1a 6b e8 f8 94 5b 24 4d a2 ...].K...[SM.
0080 73 68 25 9f 07 37 a5 3f 17 7d 04 08 a4 cc 65 32 ...].K...}....0
0090 cd cb 39 4d 95 55 35 9c 1f 83 b4 65 54 60 1a 2d ...].SM.US...eT/
00a0 f0 47 15 a5 5c da 1f e2 db 9a 8e 3e b5 74 b4 71 ...].G...>.t.
00b0 98 47 15 5c 11 ed 16 75 ac a5 b1 12 80 a3 50 3c ...].G...}....t.
00c0 9d 19 16 09 f6 c0 ff 23 36 b3 80 05 c0 a3 73 cb ...].#...Y.
00d0 07 60 81 76 9b 73 00 44 52 e6 c0 af cf 2a 04 05 ...].v.S.D R...*.
00e0 a5 cc 23 5d 7d 4b 31 20 d8 b2 ee f2 f6 ca 44 61 ...].]X1...Da
00f0 2a 5f 1f 42 1b 5f 44 01 7e 3c 9d 1f 1c 14 5a 7c ...].B.D...<.Z]
0100 ec 9e 2d 2d 4c 32 d9 9a ...].2.st.
  
```

LTE-RLC

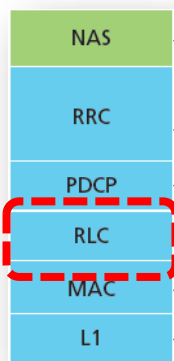

<http://wiki.wireshark.org/RLC-LTE>

Wireshark+Dissectors

No. .	Time	DCT Time	Source	Destination	Protocol	Info
1	0.000000	13.0193	PDCP_LTE_UE_RTP		PDCP-LTE ROHC(RTP)	[UL] [AM] UEId=49152 DRB:1 User: (mode=U) sn=0 IR
3	0.019400	13.0387	PDCP_LTE_UE_RTP		PDCP-LTE ROHC(RTP)	[UL] [AM] UEId=49152 DRB:1 User: (mode=U) sn=1 IR
5	0.039400	13.0587	PDCP_LTE_UE_RTP		PDCP-LTE ROHC(RTP)	[UL] [AM] UEId=49152 DRB:1 User: (mode=U) sn=2 IR
7	0.059400	13.0787	PDCP_LTE_UE_RTP		PDCP-LTE ROHC(RTP)	[UL] [AM] UEId=49152 DRB:1 User: (mode=U) sn=3 IRDYN
9	0.079400	13.0987	PDCP_LTE_UE_RTP		PDCP-LTE ROHC(RTP)	[UL] [AM] UEId=49152 DRB:1 User: (mode=U) sn=4 IRDYN
11	0.099400	13.1187	PDCP_LTE_UE_RTP		PDCP-LTE ROHC(RTP)	[UL] [AM] UEId=49152 DRB:1 User: (mode=U) sn=5 IRDYN
13	0.119400	13.1387	PDCP_LTE_UE_RTP		PDCP-LTE ROHC(RTP)	[UL] [AM] UEId=49152 DRB:1 User: (mode=U) sn=6 U0-0 (sn=7)
15	0.139400	13.1587	PDCP_LTE_UE_RTP		PDCP-LTE ROHC(RTP)	[UL] [AM] UEId=49152 DRB:1 User: (mode=U) sn=7 U0-0 (sn=8)
17	0.159400	13.1787	PDCP_LTE_UE_RTP		PDCP-LTE ROHC(RTP)	[UL] [AM] UEId=49152 DRB:1 User: (mode=U) sn=8 U0-0 (sn=9)
19	0.179400	13.1987	PDCP_LTE_UE_RTP		PDCP-LTE ROHC(RTP)	[UL] [AM] UEId=49152 DRB:1 User: (mode=U) sn=9 U0-0 (sn=10)
21	0.199400	13.2187	PDCP_LTE_UE_RTP		PDCP-LTE ROHC(RTP)	[UL] [AM] UEId=49152 DRB:1 User: (mode=U) sn=10 U0-0 (sn=11)
23	0.219400	13.2387	PDCP_LTE_UE_RTP		PDCP-LTE ROHC(RTP)	[UL] [AM] UEId=49152 DRB:1 User: (mode=U) sn=11 U0-0 (sn=12)
25	0.239400	13.2587	PDCP_LTE_UE_RTP		PDCP-LTE ROHC(RTP)	[UL] [AM] UEId=49152 DRB:1 User: (mode=U) sn=12 U0-0 (sn=13)
27	0.259400	13.2787	PDCP_LTE_UE_RTP		PDCP-LTE ROHC(RTP)	[UL] [AM] UEId=49152 DRB:1 User: (mode=U) sn=13 U0-0 (sn=14)

```

▶ Frame 21 (103 bytes on wire, 103 bytes captured)
▶ Catapult DCT2000 packet context=PDCP_LTE_UE_RTP.2 t=13.2187 S prot=pdcp_r8_lte (v=1)
RLC Op: [UL] [AM] (96)
UE Id: 49152
drbid: 1
MUI: 10
CNF: No
Discard Req: No
▼ PDCP-LTE
▶ [Configuration: (direction=Downlink, plane=User, mode=U, profile=RTP)]
1... .. = PDU Type: Data PDU (0x01)
.000 .. = Reserved: 0x00
... 0000 0000 1010 = Seq Num: 10
▼ ROHC Message (U0-0)
.101 1... = SN: 11
.... .000 0000 0000 = Large-CID: 0
IP-ID: 0x000a (10)
UDP Checksum: 0x6662 (26210)
Payload: F0454903F0036D78CC8C69AF2A00
  
```

0000	50 44 43 50 5f 4c 54 45 5f 55 45 5f 52 54 50 00
0010	02 31 33 2e 32 31 38 37 00 70 64 63 70 5f 72 38
0020	5f 6c 74 65 00 31 00 30 2c 32 2c 31 32 2c 31 2c
0030	34 2c 31 2c 31 2c 31 2c 31 2c 31 2c 31 00 00 00
0040	60 10 05 c0 00 01 01 01 35 02 00 0a 00 45 01 00
0050	41 80 0a 5f 00 00 0a 66 62 f0 45 49 03 f0 03 6d
0060	78 cc 8c 69 af 2a 00

LTE-PDCP

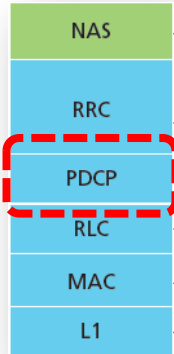

TO BE CONTINUED...