

# Otras modificaciones a 802.1Q

upna

Universidad Pública de Navarra  
Nafarroako Unibertsitate Publikoa

**Redes de Nueva Generación**  
*Área de Ingeniería Telemática*

# Extended Bridges

# 802.1BR Extended Bridge

- 802.1BR-2012 “Bridge Port Extension”
- Inicialmente 802.1Qbh (modificación a 802.1Q) pero lo cancelaron y lo movieron a un estándar independiente
- Introduce el *Extended Bridge*, que es simplemente un puente 802.1Q
- Está formado por *Controlling Bridge* y uno o más *Bridge Port Extenders*
- Forman un árbol con el Controlling Bridge como raíz (no STP interno)
- Todo ello forma un puente 802.1Q (el Extended Bridge) (...)
- Todo el extended bridge se gestiona como una unidad

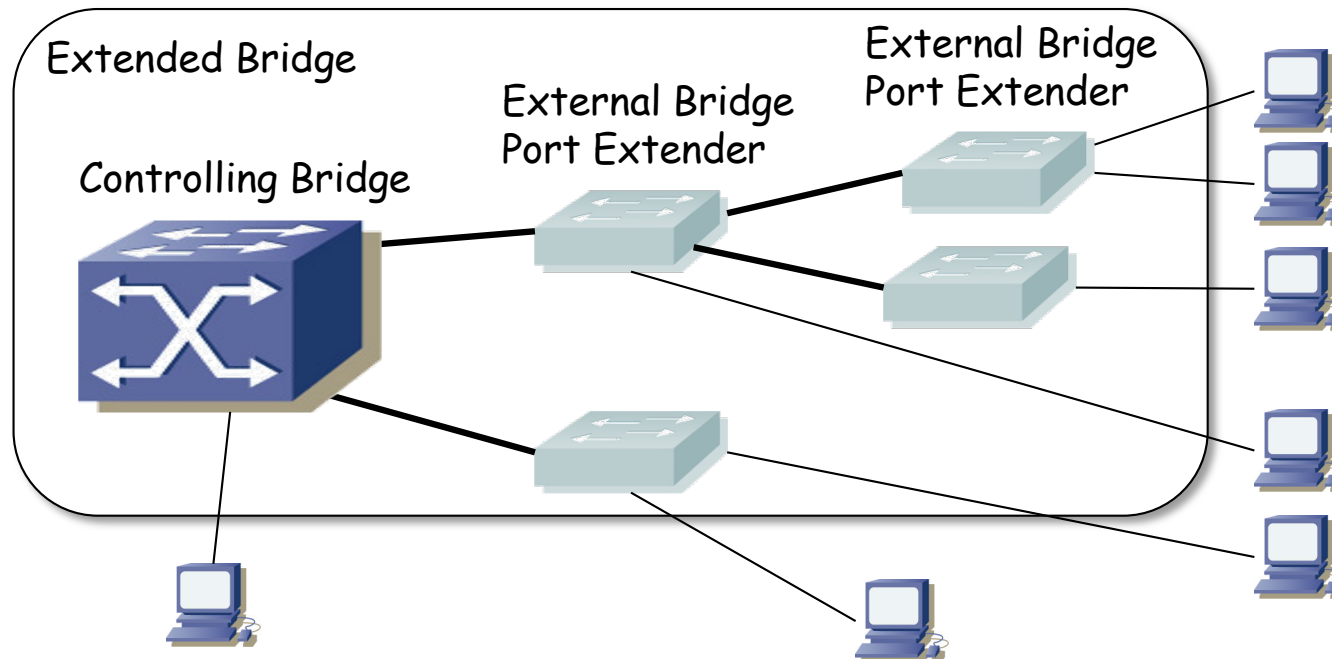

# Extended Bridge

- Todos los puertos de los PE tienen su imagen en puertos internos del Controlling Bridge
- El camino bidireccional desde el puerto externo al interno en el Controlling Bridge se llama un *E-channel* (...)
- El tráfico se conmuta en el Controlling Bridge

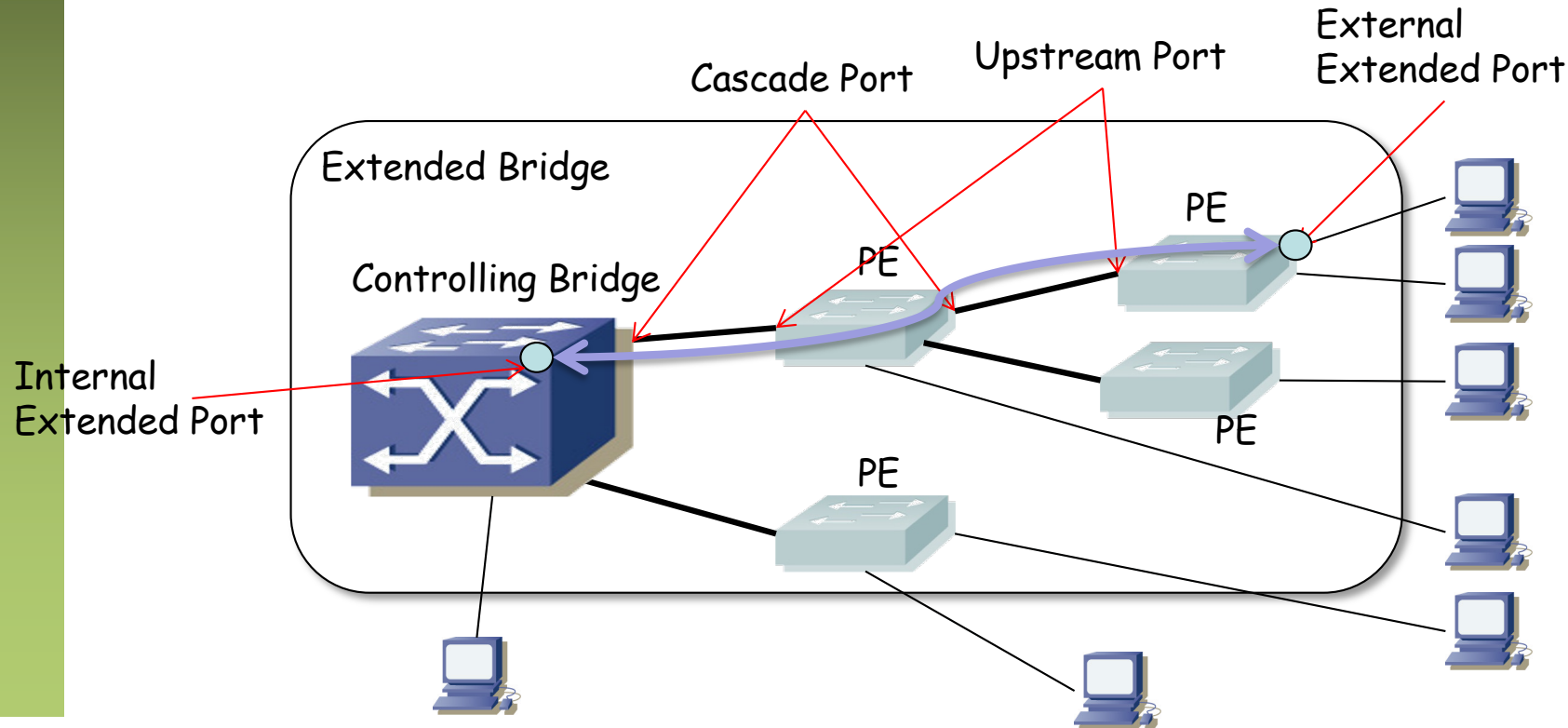

# Extended Bridge

- Un E-channel se identifica por un E-channel Identifier (E-CID)
- A una trama que entra por un Extended Port se le añade un E-Tag
- Entre otros aspectos permite identificar al puerto por el que entró la trama (de hecho al E-channel)

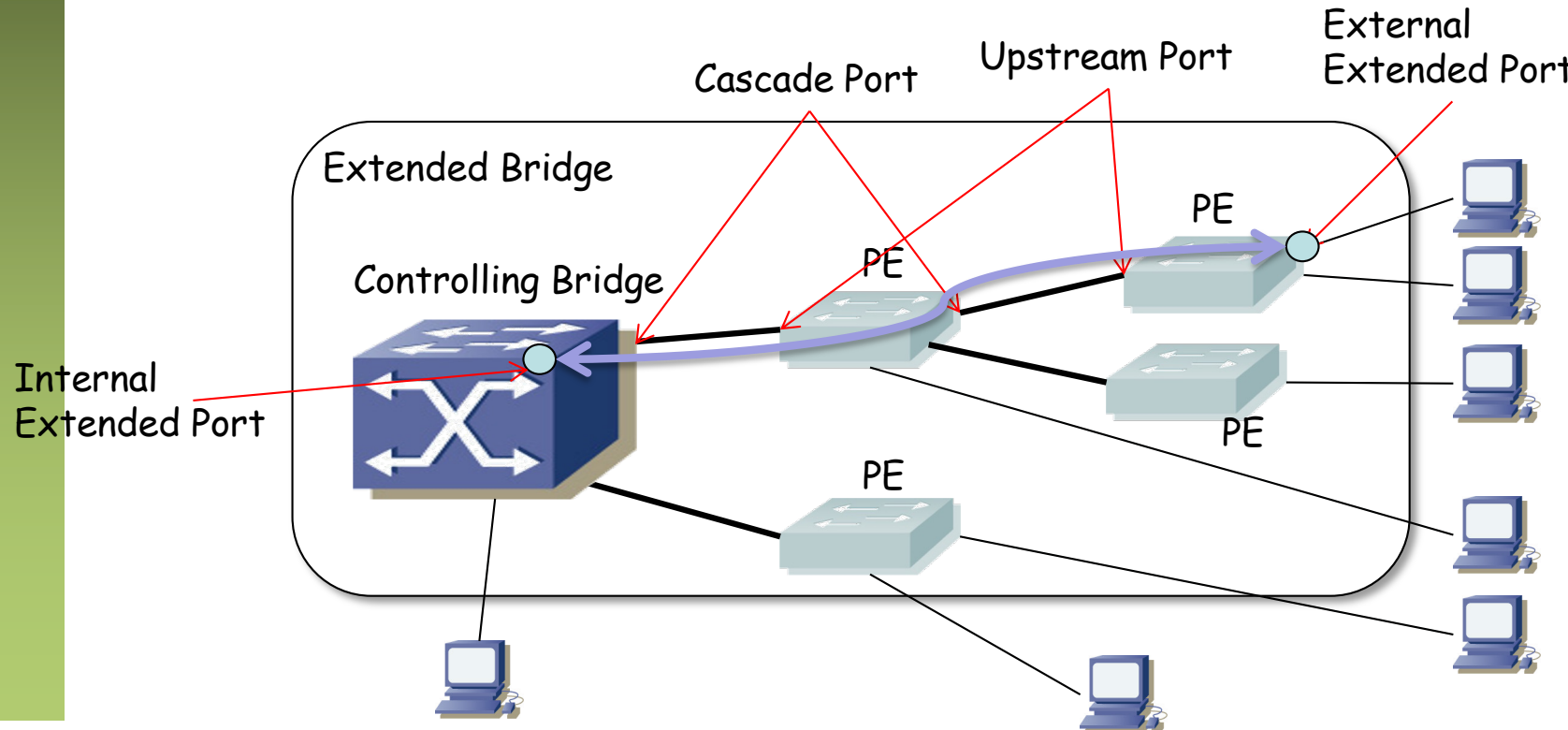
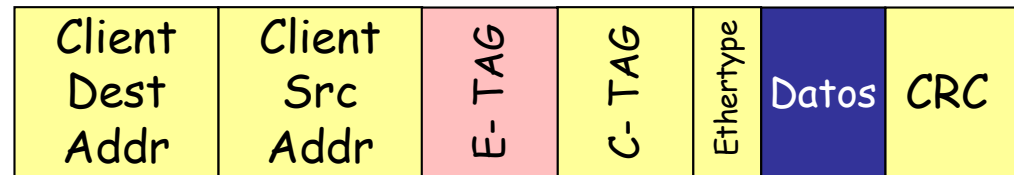

upna

Universidad Pública de Navarra  
Nafarroako Unibertsitate Publikoa

Redes de Nueva Generación  
*Área de Ingeniería Telemática*

# Extended Bridges

upna

Universidad Pública de Navarra  
Nafarroako Unibertsitate Publikoa

**Redes de Nueva Generación**  
*Área de Ingeniería Telemática*

# Virtual Birdging

# 802.1Qbg EVB

- 802.1Qbg-2012 “Edge Virtual Bridging”, ya en 802.1Q-2014
- El hypervisor además de hacer de VEB (*Virtual Edge Bridge*) puede hacer de VEPA (*Virtual Edge Port Aggregator*)
- Se busca que el switch físico se encargue de conmutar el tráfico incluso entre las VMs del mismo host (resulta en mayor utilización de los enlaces)
- Es decir, el VEPA no conmuta internamente sino que manda al exterior
- El switch físico suele poder implementar más políticas que los switches software
- ¡ El switch debe reenviar tráfico por el mismo puerto por el cual le llegó ! (*reflective relay* o *hairpin turns*)

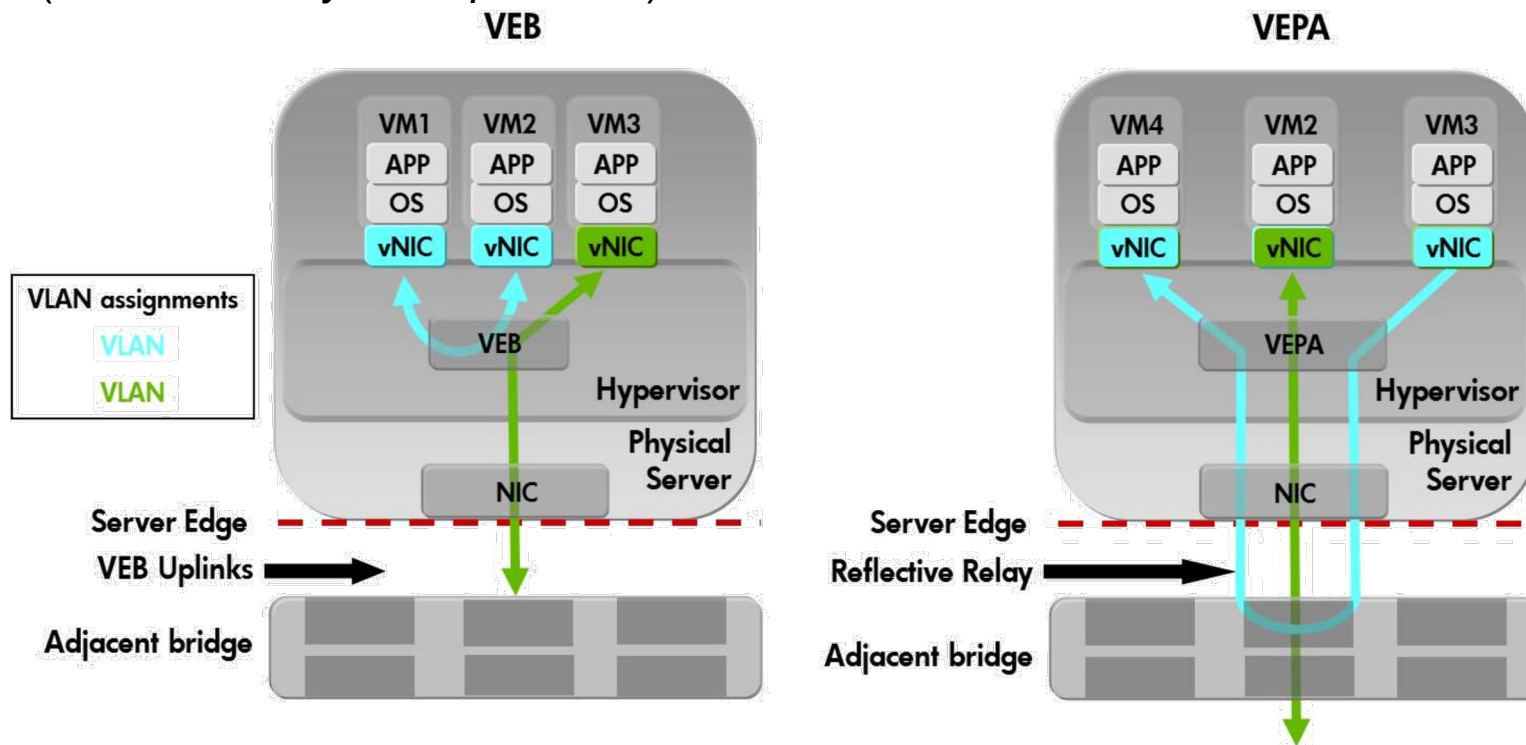



upna

Universidad Pública de Navarra  
Nafarroako Unibertsitate Publikoa

**Redes de Nueva Generación**  
*Área de Ingeniería Telemática*

# Virtual Bridging

upna

Universidad Pública de Navarra  
Nafarroako Unibertsitate Publikoa

**Redes de Nueva Generación**  
*Área de Ingeniería Telemática*

# Audio Video Bridging

# 802.1BA AVB

- Audio Video Bridging (AVB) Systems
- *“Profiles that select features, options, configurations, defaults, protocols and procedures of bridges, stations and LANs that are necessary to build networks that are capable of transporting time-sensitive audio and/or video data streams are defined in this standard.”*

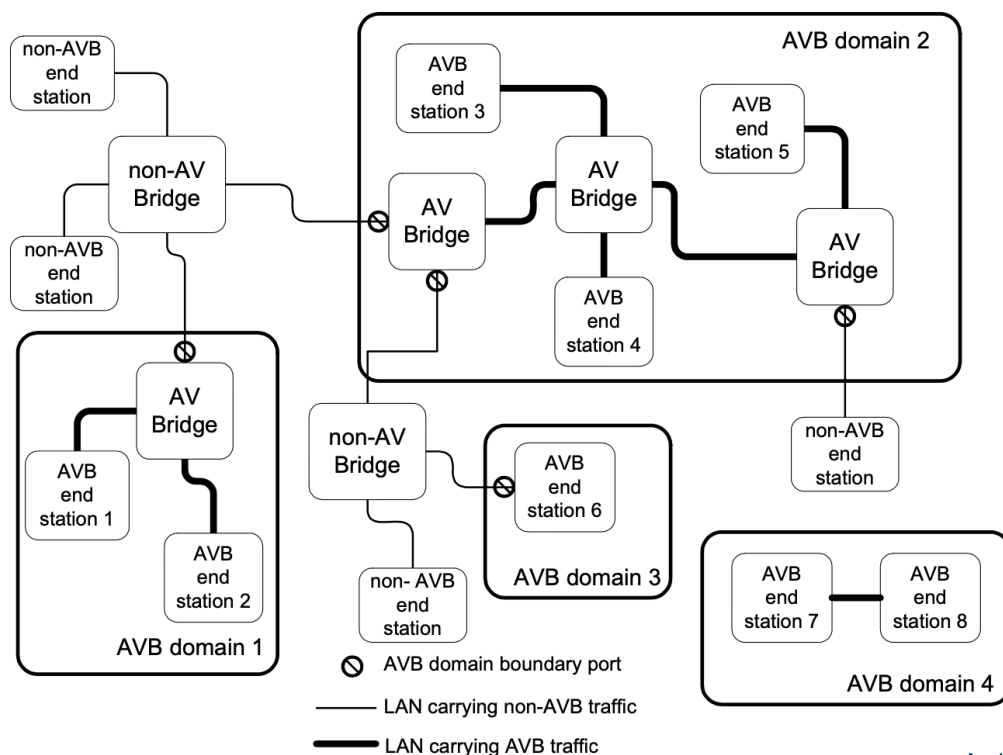

Figure 5-2—AVB domain boundaries created by non-AVB systems



## Audio Video Bridging

With Cisco IOS® XE Software Release 16.3, select\* Cisco Catalyst 3650 Series models support the IEEE 802.1 AVB standard. This standard provides the means for highly reliable delivery of low-latency, time-synchronized AV streaming services through Layer 2 Ethernet networks. The standard also makes it easier to integrate new services and for AV equipment from different vendors to interoperate. Whether the AV endpoint connections are analog or are inflexible digital one to one, the network transport enables many-to-many transparent plug-and-play connections for multiple AV endpoints.

upna

Universidad Pública de Navarra  
Nafarroako Unibertsitate Publikoa

Redes de Nueva Generación  
*Área de Ingeniería Telemática*

# Audio Video Bridging

# Time-Sensitive Networking

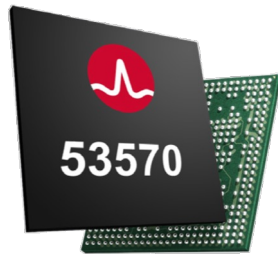

## Key Features

- Line-rate, non-blocking architecture
- High-performance ARM Cortex-A9 and R5 processors
- Flexible I/O configurations of 100M, 1.0G, 2.5G, 5G, 10G, 25G, 40G, and 50G link speeds
- Cut-through switching for low-latency applications
- Complete TSN feature implementation in industrial temp SKUs including:
  - Path control and reservation (IEEE 802.1Qca)
  - Time aware shaper (IEEE 802.1Qbv)
  - Frame preemption (IEEE 802.1Qbu/IEEE 802.3br)
  - Cyclic queuing and forwarding (IEEE 802.1Qch)
  - Timing and synchronization, PTP, IEEE 802.1AS-Rev, 1588 v2
  - Stream reservation protocol enhancement (IEEE 802.1Qcc)
  - Time-based ingress policer (IEEE 802.1Qci)
  - Frame replication and elimination for reliability (IEEE 802.1CB)
  - Front-haul network profile (IEEE 802.1CM)

# Ejemplo

## BCM53570

### 380 Gb/s TSN L2 Multilayer Switch

- Integrated high-speed Arm Cortex-A9 processor, embedded Cortex-R5 processor
- Time-Sensitive Networking (TSN) features, such as Preemption, Time Aware Scheduling, and Seamless Redundancy, to provide deterministic behavior to Industrial Ethernet, 5G Wireless connectivity, and transport networks.

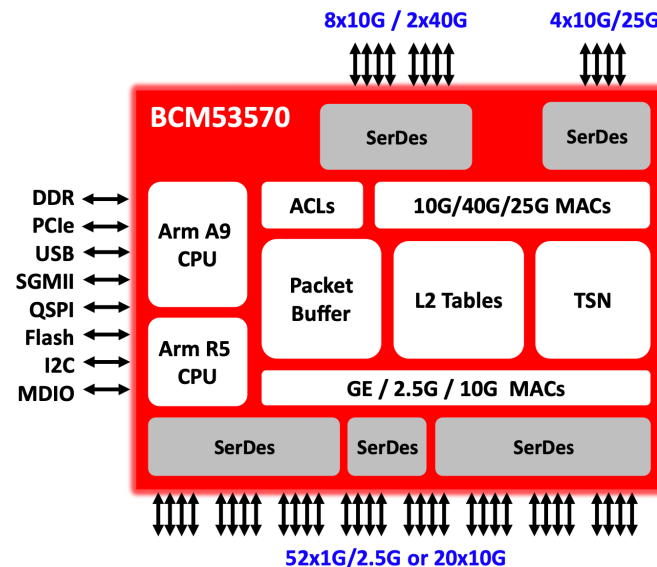

## Key Features (continued)

- Integrated HSR/PRP (High-availability Seamless Redundancy (IEC 52439-3 C4)/Parallel Redundancy Protocol (IEC 62439-3 C5))
- Support for port extender applications (IEEE 802.1br, eTAG, VNTag, HiGig™)
- Support for direct connect to IEEE 802.3bz PHY devices for 2.5 Gb/s and 5.0 Gb/s connectivity
- Layer 2, IPv4/IPv6 Layer 3, Layer 4, and User-Defined Field (UDF) based packet classification
- Priority-based Flow Control (PFC)
- Synchronized Ethernet (SyncE)
- OAM (IEEE 802.1ag and ITU-T Y.1731)

# 802.1Qca-2015

- *“Path Control and Reservation”, Amendment 24 a 802.1Q-2014*
- *“These extensions involve explicit path control, bandwidth reservation, and redundancy (protection, restoration) for data flows. Thus, this standard specifies bridging on explicit paths for unicast and multicast frames, specifying protocols to determine multiple active topologies.”*
- Extensiones a IS-IS: *ISIS-PCR (Path Control and Reservation)*
- Emplea el “Path Control Element” (PCE) definido por el IETF PCE WG
- El PCE es un puente o un host

# 802.1Qbv-2015

- *“Enhancements for Scheduled Traffic”, Amendment 25 a 802.1Q-2014*
- *“Some applications have a need for frame **delivery that is highly predictable** in terms of the time at which frame transmission will occur, and the overall latency and jitter ...”*
- *Examples include **industrial and automotive control applications**, where data transmitted over the network is used to feed the parameters of control loops that are critical to the operation of the plant or machinery involved, ...*
- *In some implementations, this need has been met by the provision of dedicated, highly engineered networks [...] however, [...] it can be desirable to mix time-critical traffic with other classes of traffic in the same network, ...*
- *... ensure that, at specific times, only one traffic class (or set of traffic classes) has access to the network; in effect to create a protected “channel” that is used by that traffic class alone.*

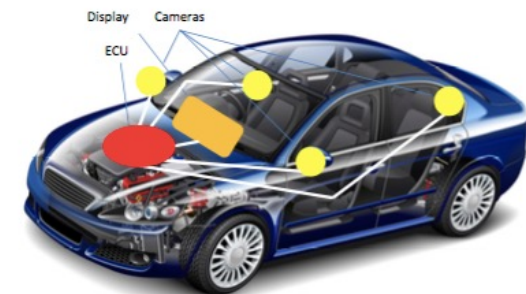



# 802.1Qbu-2016

- *“Frame Preemption”, Amendment 26 a 802.1Q-2014*
- *Enhancements to the forwarding process that support frame preemption*
- ***preemption***: *The suspension of the transmission of a preemptable frame to allow one or more express frames to be transmitted before transmission of the preemptable frame is resumed.*
- *eMAC = express MAC*
- *pMAC = preemptable MAC*
- *Acompaña a 802.3br-2015 “Specification and Management Parameters for Interspersing Express Traffic”*

# 802.1Qch-2017

- “Cyclic Queuing and Forwarding”, Amendment 29 a 802.1Q-2014
- “Cyclic queuing and forwarding (CQF) is a method of **traffic shaping** that can deliver deterministic, and easily calculated, latency for time-sensitive traffic streams.
- ... stream traffic is transmitted and queued for transmission along a network path in a cyclic manner.
- **Time is divided into numbered time intervals  $i$ ,  $i+1$ ,  $i+2$ , ...  $i+N$ , each of duration  $d$ .**
- Frames transmitted by a Bridge, Alice, during time interval  $i$  are **received** by a downstream Bridge, Bob, **during time interval  $i$**  and **are transmitted** onwards by Bob towards Bridge Charlie **during time interval  $i+1$** , and so on.
- A starting assumption is that, for a given traffic class, all Bridges and all end stations connected to a given bridge have a common understanding (to a known accuracy) of the start time of cycle  $i$ , and the cycle duration,  $d$ .”

# 802.1Qci-2017

- “Per-Stream Filtering and Policing”, Amendment 28 a 802.1Q-2014
- “Enhancements to the forwarding process that support per-stream filtering and policing”

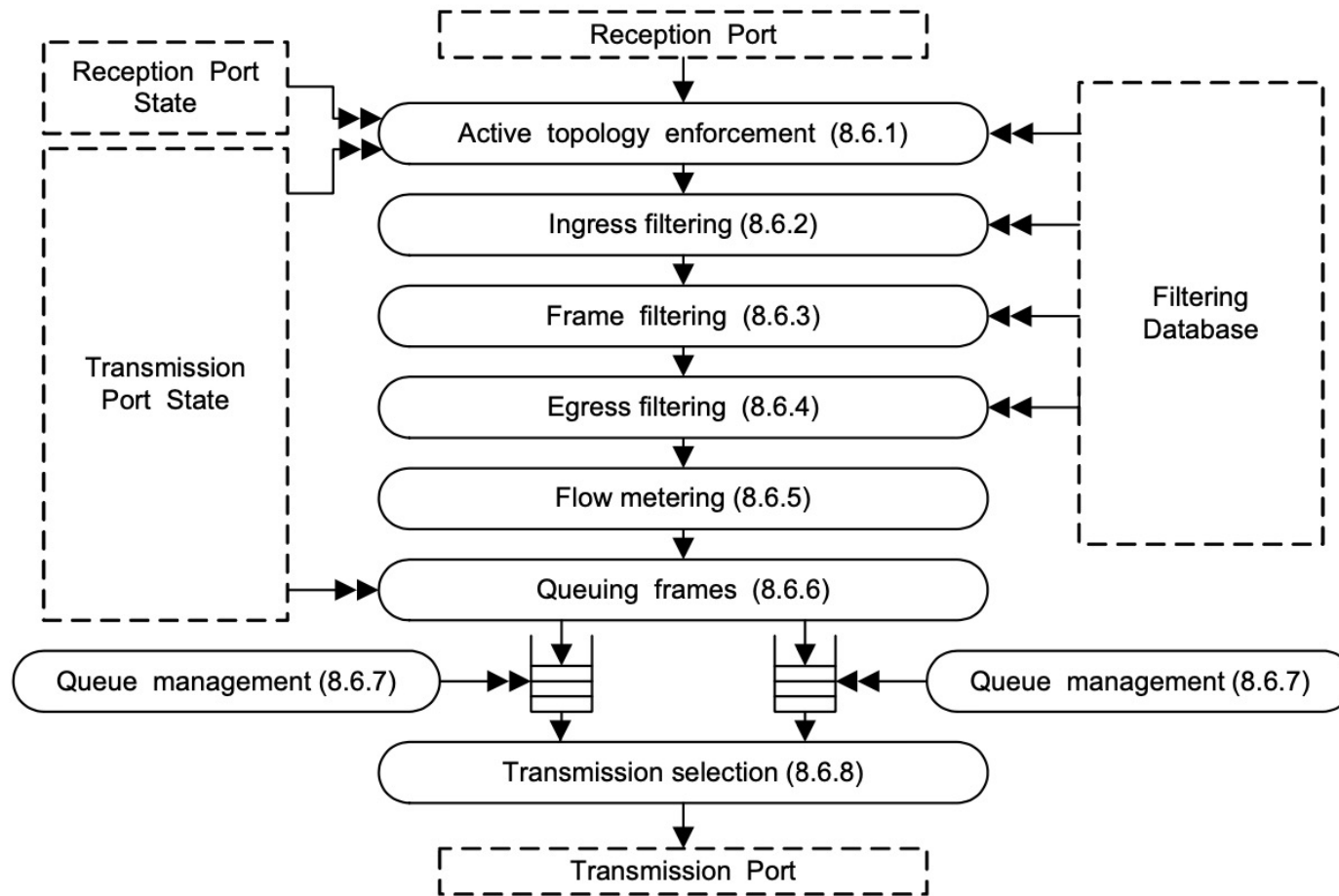

Figure 8-11—Forwarding process functions

# 802.1Qci-2017

- “Per-Stream Filtering and Policing”, Amendment 28 a 802.1Q-2014

## 8.6.5.1.3 Flow meter instance table

The flow meter instance table contains a set of parameters for each flow meter instance. The parameters for each flow meter instance are as specified in *Bandwidth Profile Parameters and Algorithm* in MEF 10.3, plus some additional parameters, as follows:

NOTE—Envelope and Rank, as defined in MEF 10.3, are not used for PSFP; i.e., PSFP uses the reduced functionality algorithm described in 12.2 of MEF 10.3.

- a) *Flow meter instance identifier*. An integer value identifying the flow meter instance.
- b) *Committed information rate (CIR)*, in bits per second.
- c) *Committed burst size (CBS)*, in octets.
- d) *Excess Information Rate (EIR)*, in bits per second.
- e) *Excess burst size (EBS) per bandwidth profile flow*, in octets.
- f) *Coupling flag (CF)*, which takes the value 0 or 1.
- g) *Color mode (CM)*, which takes the value *color-blind* or *color-aware*.
- h) *DropOnYellow*, which takes the value TRUE or FALSE. A value of TRUE indicates that yellow frames are dropped (i.e., discarded); a value of FALSE indicates that yellow frames will have the *drop\_eligible* parameter set to TRUE.
- i) *MarkAllFramesRedEnable*, which takes the value TRUE or FALSE. A value of TRUE indicates that the *MarkAllFramesRed* function is enabled; a value of FALSE indicates that the *MarkAllFramesRed* function is disabled. The default value of *MarkAllFramesRedEnable* is FALSE.
- j) *MarkAllFramesRed*, which takes the value TRUE or FALSE. If *MarkAllFramesRedEnable* is TRUE, a value of TRUE in *MarkAllFramesRed* indicates that all frames are dropped (i.e., discarded). If *MarkAllFramesRed* is False, it has no effect. The default value of *MarkAllFramesRed* is FALSE; if the operation of the flow meter causes any frame to be discarded, then *MarkAllFramesRed* is set TRUE.

# 802.1Qcc-2018

- “Stream Reservation Protocol (SRP) Enhancements and Performance Improvements”, Amendment 31 8 802.1Q-2014
- “This standard specifies enhancements to protocols, procedures, and managed objects for the configuration of network resources for time-sensitive (i.e., bounded latency) applications. “
- “The enhancements address Time-Sensitive Networking (TSN) application requirements beyond audio/video (AV) traffic. “

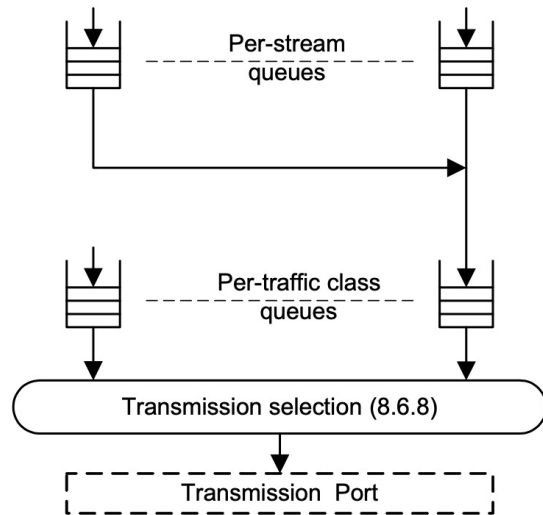

Figure 34-1—Queuing model for a Talker station

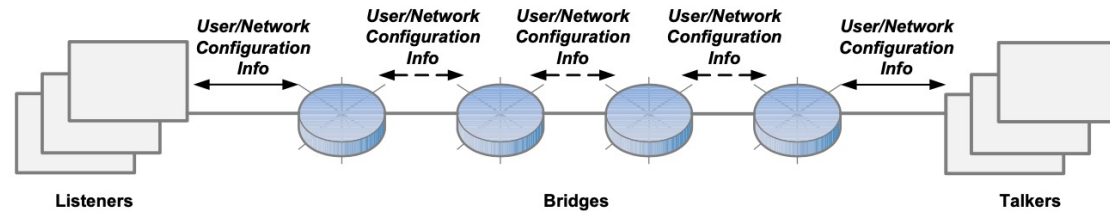

Figure 46-1—Fully distributed model

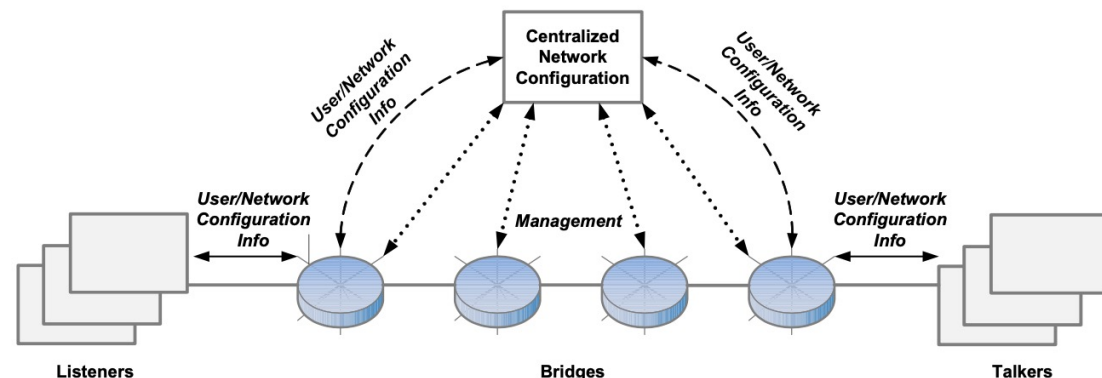
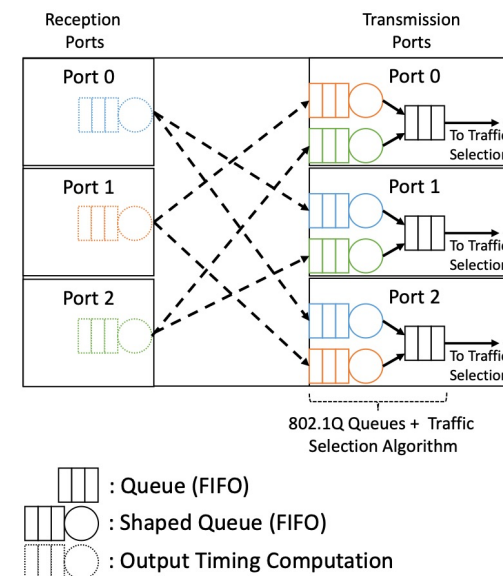

Figure 46-2—Centralized network/distributed user model

# 802.1Qcr-2020

- *“Asynchronous Traffic Shaping”*
- *“This amendment to IEEE Std 802.1Q-2018 specifies procedures and managed objects for Bridges and end stations to perform Asynchronous Traffic Shaping over full-duplex links with constant bit data rates.”*
- *“Asynchronous Traffic Shaping can be modeled as a layer of shaped first-in-first-out (FIFO) queues that are merged into per traffic class FIFO queues in transmission ports.”*
- *“Additionally, this amendment provides an informative framework for worst-case delay analysis in static networks with static configurations.”*



# 802.1Qcz-2023

- Amendment 35: Congestion Isolation
- “... support the isolation of congesting data flows within data center environments.”
- “Congestion isolation capable systems identify flows creating congestion, adjust transmission selection for packets of those flows, and signal to neighbors”
- “This mechanism reduces head-of-line blocking for non-congesting flows sharing a traffic class in lossless networks.
- “Congestion Isolation is intended to be used with higher layer protocols that utilize end-to-end congestion control in order to reduce packet loss and latency.”

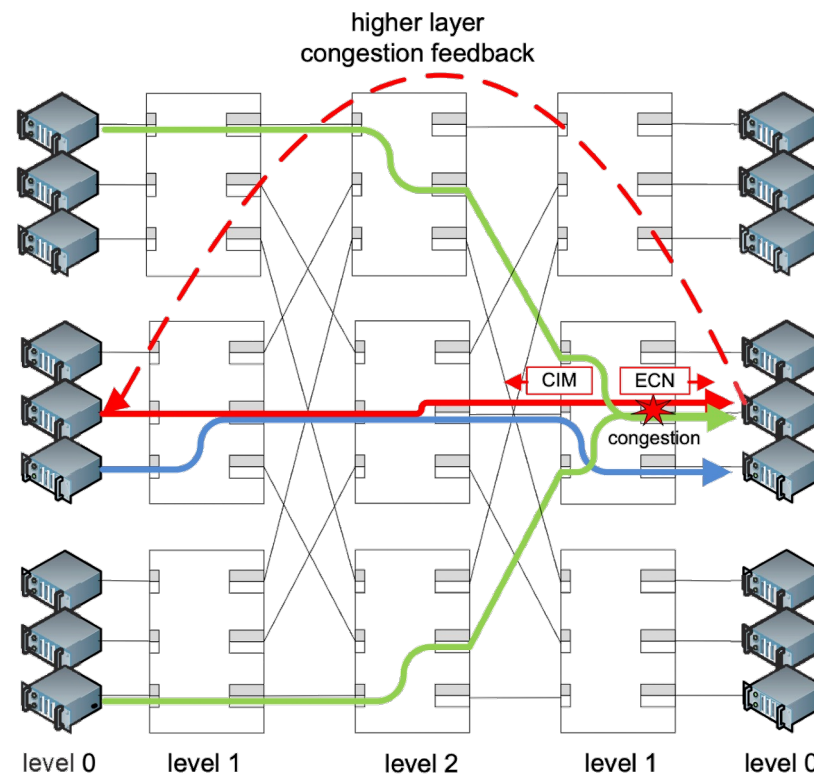

Figure 49-1—Congestion Isolation example operation

# Time-Sensitive Networking



# Otras modificaciones a 802.1Q